

Unger Technologies Machine/Test sound enclosures are the solution for noisy equipment where space and access is at a premium. The Model MSE-4 sound enclosure is constructed of a free standing, aluminum extruded frame and corner fittings. Resting within the frame are 4" thick, 18 gage steel acoustical wall and roof panels. Because the frame is self supporting, all wall and roof panels are removable with quarter turn fasteners providing unrestricted access to equipment for maintenance and repair. This space saving design feature eliminates the need for areas within the enclosure for personnel. The sound enclosure walls and roof can be placed within inches of the equipment, saving valuable floor space without restricting access.

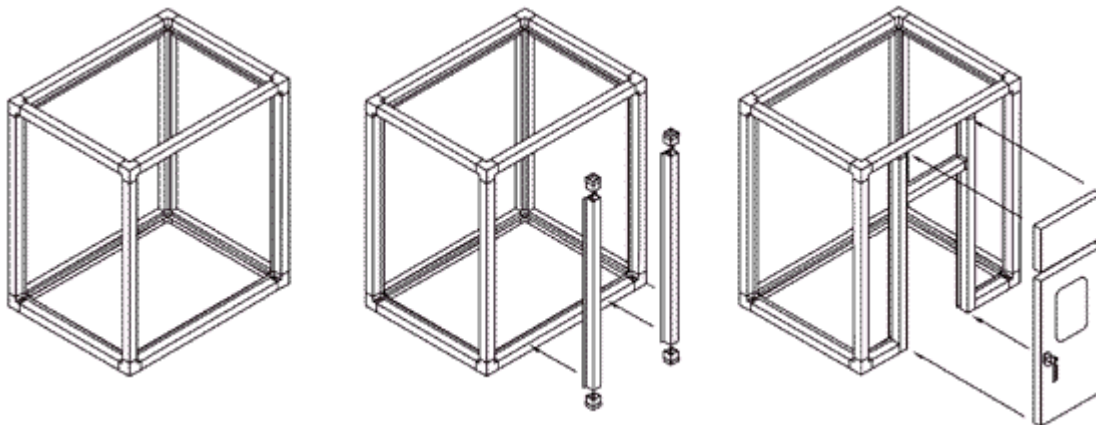

Features:

- Free Standing Framework
- Complete Panel Removability
- Easily Assembled
- Doors, Windows, and Silenced Ventilation available
- Designed and Built for your Application



Unger Technologies, Inc.

297 North 9th Street ♦ Noblesville, IN 46060
Ph: 888.213.4711 ♦ Fax: 317.774.1911