

Option A - Mounting Frame for Outdoor Sound Blankets

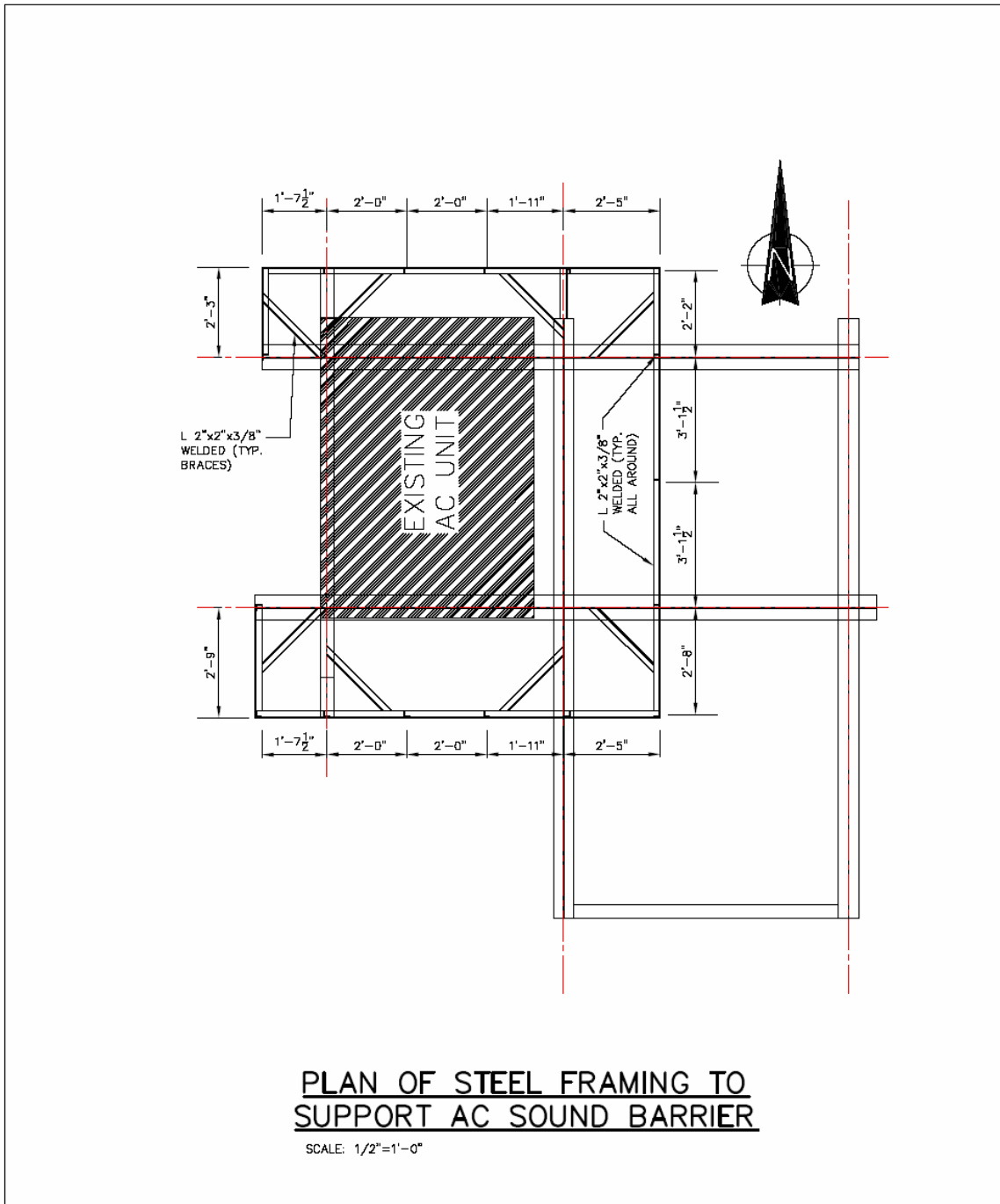

The above drawing is a representation of typical construction details and is not intended to be used without consulting with Unger Technologies Engineering Department for your specific use.

Option A Details - Mounting Frame for Outdoor Sound Blankets

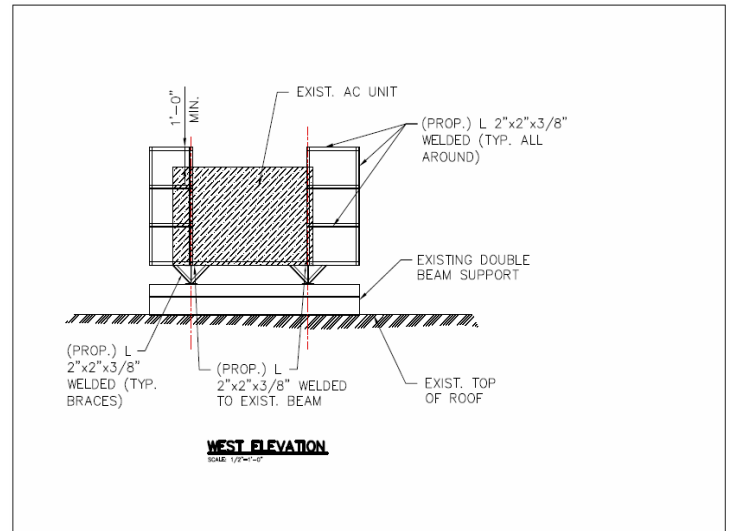
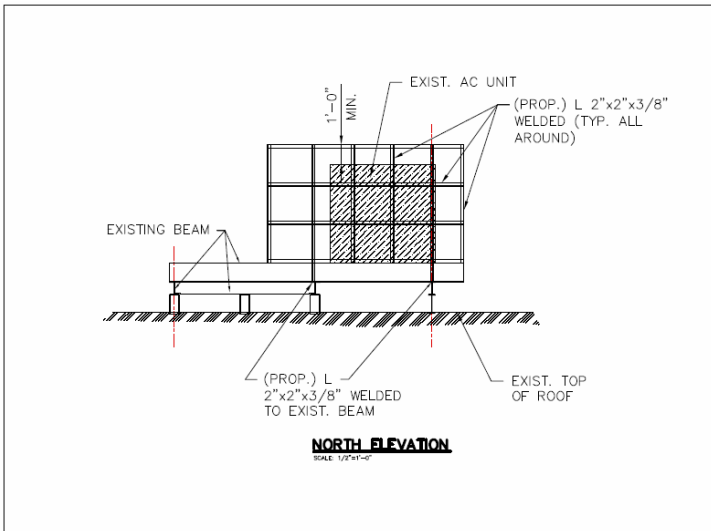
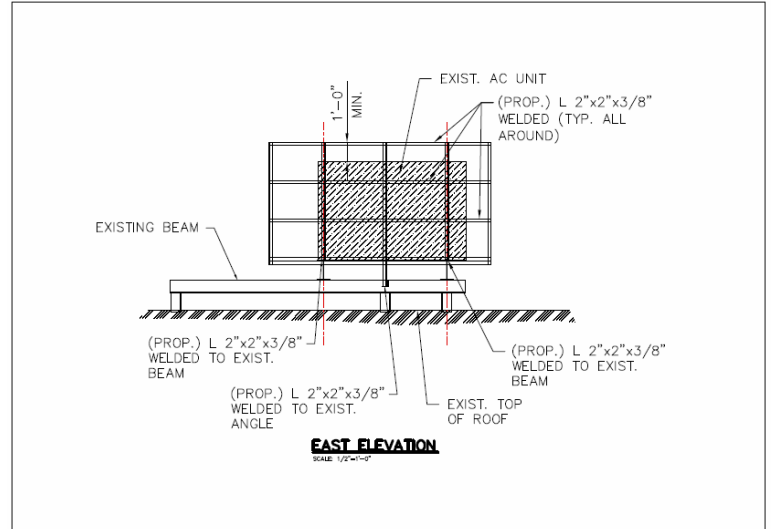
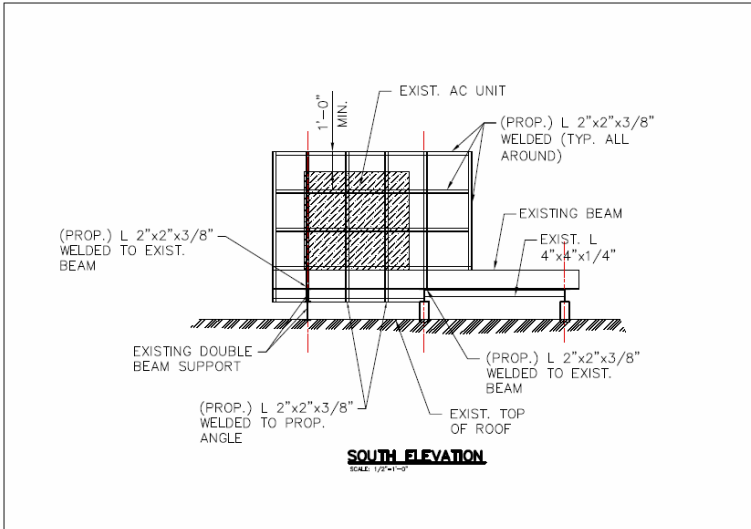

The above drawing is a representation of typical construction details and is not intended to be used without consulting with Unger Technologies Engineering Department for your specific use.

Option B - Mounting Frame for Outdoor Sound Blankets

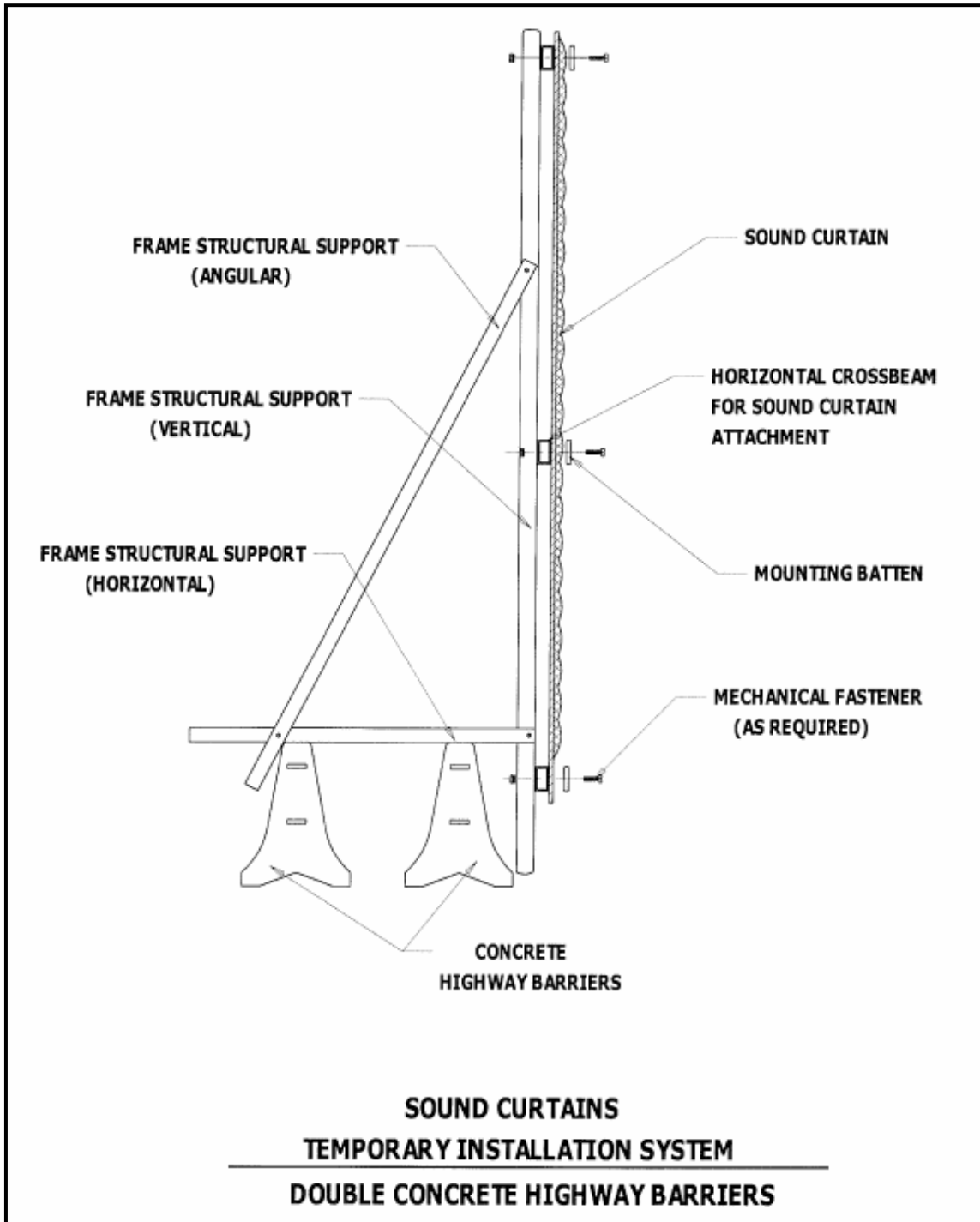

The above drawing is a representation of typical construction details and is not intended to be used without consulting with Unger Technologies Engineering Department for your specific use.

Option B Details - Mounting Frame for Outdoor Sound Blankets

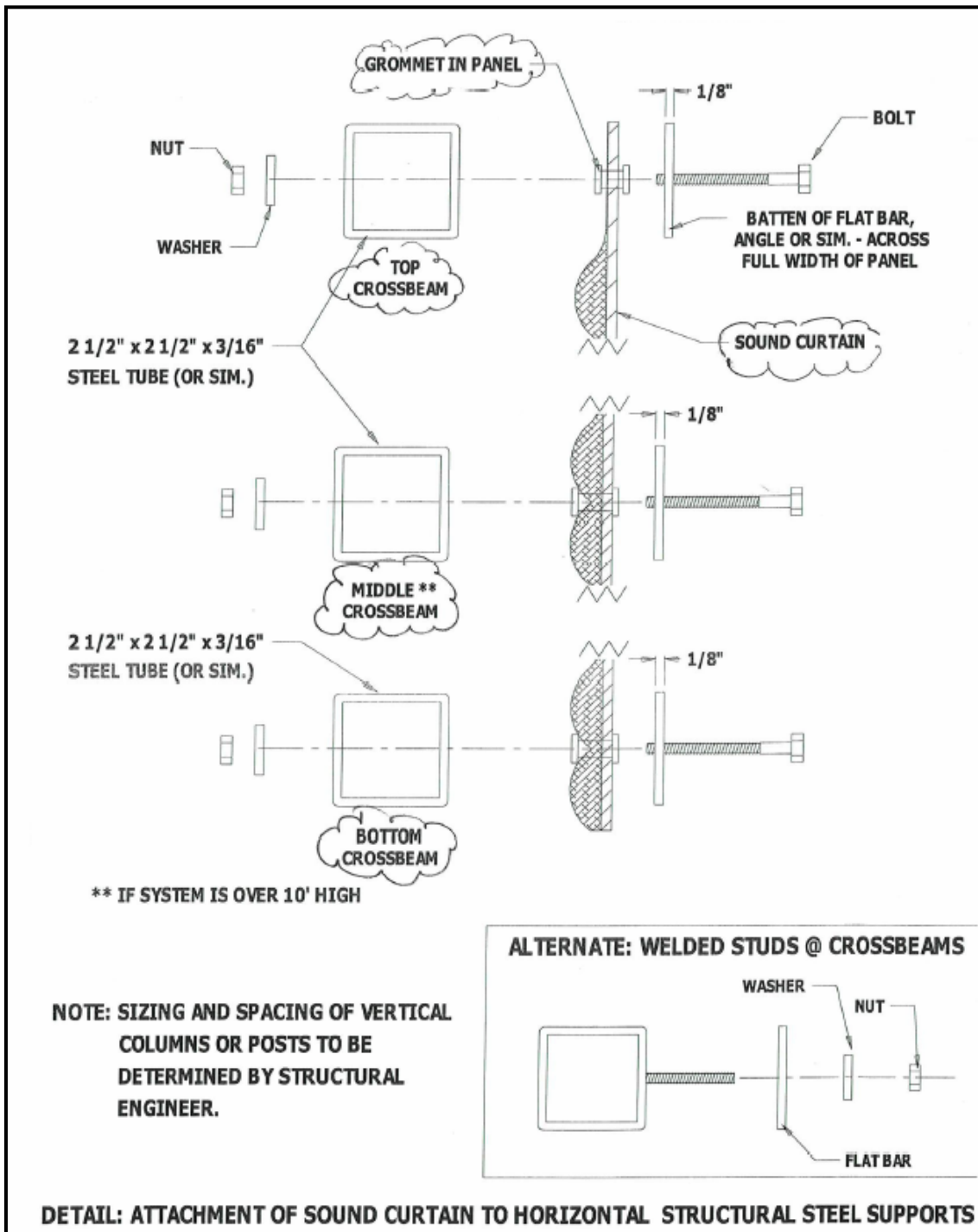

The above drawing is a representation of typical construction details and is not intended to be used without consulting with Unger Technologies Engineering Department for your specific use.